

***HT400<sup>®</sup> /***

***HT4000<sup>®</sup> /***

***H4001<sup>®</sup>***

***Air Injected  
Water Muffler  
System***

***Instruction Manual  
801730 - Rev. 2***

***HYPERTHERM<sup>®</sup>***  

**HT400<sup>®</sup>/HT4000<sup>®</sup>/HT4001<sup>®</sup>**  
**Air Injected**  
**Water Muffler**  
**System**

**Instruction Manual**  
**IM-173**  
**(P/N 801730)**

**for systems**  
**beginning with**  
**serial numbers**  
**0767 (HT400)**  
**4000-00000 (HT4000)**  
**4001-00000 (HT4001)**

**Revision 2 April, 1995**

**HYPERTHERM, Inc.**  
**P.O. Box 5010**  
**Hanover, New Hampshire 03755-5010**  
**Tel.: (603) 643-3441**  
**Fax: (603) 643-5352**

**© Copyright 1995 Hypertherm, Inc.**  
**All Rights Reserved**

**HYPERTHERM and HT are trademarks of Hypertherm, Inc. and are**  
**registered in the United States; International registrations are pending.**

**Hypertherm, Inc.**  
Etna Road, P.O. Box 5010  
Hanover, NH 03755 USA  
603-643-3441 Tel (Main Office)  
603-643-5352 Fax (All Departments)  
**800-643-9878 Tel (Technical Service)**  
800-737-2978 Tel (Customer Service)

**Hypertherm Automation**  
5 Technology Drive  
West Lebanon, NH 03755 USA  
603-298-7970 Tel  
603-298-7977 Fax

**Hypertherm Plasmatechnik GmbH**  
Technologiepark Hanau  
Rodenbacher Chaussee 6  
63457 Hanau-Wolfgang, Deutschland  
49 6181 58 2100 Tel  
49 6181 58 2134 Fax  
**49 6181 58 2123 (Technical Service)**

**Hypertherm Singapore Pte Ltd**  
No. 19 Kaki Bukit Road 2  
K.B. Warehouse Complex  
Singapore 417847, Republic of Singapore  
65 841 2489 Tel  
65 841 2490 Fax  
**65 841 2489 (Technical Service)**

**Japan**  
1952-14 Yata-Natsumegi  
Mishima City, Shizuoka Pref.  
411-0801 Japan  
81 0 559 75 7387 Tel  
81 0 559 75 7376 Fax

**Hypertherm UK Ltd**  
9 Berkeley Court, Manor Park  
Runcorn, Cheshire, England WA7 1TQ  
44 1928 579 074 Tel  
44 1928 579 604 Fax

**France**  
15 Impasse des Rosiers  
95610 Eragny, France  
0805 050 111 Tel  
0805 050 222 Fax

**Hypertherm S.r.L.**  
Via Torino 2  
20123 Milano, Italia  
39 02 725 46 312 Tel  
39 02 725 46 400 Fax  
**39 02 725 46 314 (Technical Service)**

**Hypertherm B.V.**  
Burg. Haverkampstraat 13  
7091 CN Dinxperlo, Nederland  
31 315 655866 Tel  
31 315 655886 Fax

**Hypertherm B.V. (ETSO)**  
Vaartveld 9  
4704 SE Roosendaal, Nederland  
**00 800 49 73 7843 - toll-free in Europa**  
31 165 596900 Tel  
31 165 596901 Fax

**Hypertherm Brasil Ltda.**  
Rua Visconde de Santa Isabel, 20 - Sala 611  
Vila Isabel, RJ  
Brasil CEP 20560-120  
55 21 2278 6162 Tel  
55 21 2578 0947 Fax



## ATTENTION



**Genuine Hypertherm parts are the factory-recommended replacement parts for your Hypertherm system. Any damage caused by the use of other than genuine Hypertherm parts is not covered by the Hypertherm warranty.**

## WARRANTY

---

### WARNING

Genuine Hypertherm parts are the factory-recommended replacement parts for your Hypertherm system. Any damage caused by the use of other than genuine Hypertherm parts may not be covered by the Hypertherm warranty.

### WARNING

You are responsible for the safe use of the Product. Hypertherm does not and cannot make any guarantee or warranty regarding the safe use of the Product in your environment.

### GENERAL

Hypertherm, Inc. warrants that its Products shall be free from defects in materials and workmanship, if Hypertherm is notified of a defect (i) with respect to the power supply within a period of two (2) years from the date of its delivery to you, with the exception of G3 Series power supplies, which shall be within a period of three (3) years from the date of delivery to you, and (ii) with respect to the torch and leads within a period of one (1) year from its date of delivery to you. This warranty shall not apply to any Product which has been incorrectly installed, modified, or otherwise damaged. Hypertherm, at its sole option, shall repair, replace, or adjust, free of charge, any defective Products covered by this warranty which shall be returned with Hypertherm's prior authorization (which shall not be unreasonably withheld), properly packed, to Hypertherm's place of business in Hanover, New Hampshire, or to an authorized Hypertherm repair facility, all costs, insurance and freight prepaid. Hypertherm shall not be liable for any repairs, replacement, or adjustments of Products covered by this warranty, except those made pursuant to this paragraph or with Hypertherm's prior written consent. **The warranty above is exclusive and is in lieu of all other warranties, express, implied, statutory, or otherwise with respect to the Products or as to the results which may be obtained therefrom, and all implied warranties or conditions of quality or of merchantability or fitness for a particular purpose or against infringement. The foregoing shall constitute the sole and exclusive remedy for any breach by Hypertherm of its warranty.** Distributors/OEMs may offer different or additional warranties, but Distributors/OEMs are not authorized to give any additional warranty protection to you or make any representation to you purporting to be binding upon Hypertherm.

### PATENT INDEMNITY

Except only in cases of products not manufactured by Hypertherm or manufactured by a person other than Hypertherm not in strict conformity with Hypertherm's specifications and in cases of designs, processes, formulae, or combinations not developed or purported to be developed by Hypertherm, Hypertherm will defend or settle, at its own expense, any suit or proceeding brought against you alleging that the use of the Hypertherm product, alone and not in combination with any other product not supplied by

Hypertherm, infringes any patent of any third party. You shall notify Hypertherm promptly upon learning of any action or threatened action in connection with any such alleged infringement, and Hypertherm's obligation to indemnify shall be conditioned upon Hypertherm's sole control of, and the indemnified party's cooperation and assistance in, the defense of the claim.

### LIMITATION OF LIABILITY

**In no event shall Hypertherm be liable to any person or entity for any incidental, consequential, indirect, or punitive damages (including but not limited to lost profits) regardless of whether such liability is based on breach of contract, tort, strict liability, breach of warranties, failure of essential purpose or otherwise and even if advised of the possibility of such damages.**

### LIABILITY CAP

**In no event shall Hypertherm's liability, whether such liability is based on breach of contract, tort, strict liability, breach of warranties, failure of essential purpose or otherwise, for any claim action suit or proceeding arising out of or relating to the use of the Products exceed in the aggregate the amount paid for the Products that gave rise to such claim.**

### INSURANCE

At all times you will have and maintain insurance in such quantities and types, and with coverage sufficient and appropriate to defend and to hold Hypertherm harmless in the event of any cause of action arising from the use of the Products.

### NATIONAL AND LOCAL CODES

National and Local codes governing plumbing and electrical installation shall take precedent over any instructions contained in this manual. **In no event** shall Hypertherm be liable for injury to persons or property damage by reason of any code violation or poor work practices.

### TRANSFER OF RIGHTS

You may transfer any remaining rights you may have hereunder only in connection with the sale of all or substantially all of your assets or capital stock to a successor in interest who agrees to be bound by all of the terms and conditions of this Warranty.

# TABLE OF CONTENTS

---

<b>SECTION 1 SAFETY, INTRODUCTION &amp; SPECIFICATIONS .....</b>	<b>1-1</b>
Safety .....	1-2
Introduction .....	1-3
Above-Water Cutting .....	1-3
Underwater Cutting .....	1-3
System Components .....	1-3
Water Table Requirements .....	1-3
Specifications .....	1-4
<b>SECTION 2 INSTALLATION .....</b>	<b>2-1</b>
Upon Receipt .....	2-2
Damage Claims .....	2-2
Installation .....	2-3
Install Nozzle Assembly .....	2-3
Install Pump .....	2-3
Install Air Control Box .....	2-5
Installation Checkout .....	2-9
Pump Discharge Hose Water Recovery Checkout .....	2-9
Install Check Valve .....	2-10
<b>SECTION 3 OPERATION &amp; MAINTENANCE .....</b>	<b>3-1</b>
Operation .....	3-2
Daily Setup and Operation .....	3-2
Above-Water Cutting .....	3-2
Underwater Cutting .....	3-3
Maintenance .....	3-3
Nozzle Assembly .....	3-3
Pump Unit .....	3-4
Filter/Strainer .....	3-4
Pump Contactor .....	3-4
Air Control Box & Pump Contactor 120-VAC Control Signals .....	3-4
Technical Questions .....	3-4
<b>SECTION 4 PARTS LIST .....</b>	<b>4-1</b>
Water Muffler Systems .....	4-2
230/460V, 3 Ph, 60 Hz w/Hoses .....	4-2
230/460V, 3 Ph, 60 Hz w/o Hoses .....	4-2
380-415V, 3 Ph, 50 Hz w/Hoses .....	4-3
380-415V, 3 Ph, 50 Hz w/o Hoses .....	4-3
575V, 3 Ph, 60 Hz w/Hoses .....	4-4
575V, 3 Ph, 60 Hz w/o Hoses .....	4-4
Nozzle Assembly with Adapters .....	4-5
Nozzle Assembly with Swivels .....	4-6
Water Supply Assembly .....	4-7
Pump Assembly .....	4-9
Pump Discharge Hose Check Valve (Optional) .....	4-9

# TABLE OF CONTENTS

---

**APPENDIX** ..... a-1  
Water Muffler Pumps ..... a-2

**ILLUSTRATIONS**

Figure 2-1 Nozzle Assembly, Water Sleeve and Air Deflector Sleeve Installation ..... 2-4  
Figure 2-2 Filter Strainer, Optional Installation ..... 2-7  
Figure 2-3 Air Injected Water Muffler System Interconnection Diagram ..... 2-8  
Figure 4-1 Nozzle Assembly with Adapters ..... 4-5  
Figure 4-2 Nozzle Assembly with Swivels ..... 4-6  
Figure 4-3 Water Supply Assembly ..... 4-8

# Section 1 Safety, Introduction & Specifications

In this section:

---

Safety .....	1-2
Introduction .....	1-3
Above-Water Cutting .....	1-3
Underwater Cutting .....	1-3
System Components .....	1-3
Water Table Requirements .....	1-3
Specifications .....	1-4

---

# SAFETY, INTRODUCTION & SPECIFICATIONS

## SAFETY

Listed below are the basic safety precautions that should be adhered to when operating plasma equipment. Refer to the applicable HT400 or HT4000 instruction manual for detailed safety information.

### WARNING



#### **ELECTRIC SHOCK CAN KILL.**

- Do not touch live electrical parts.
- Keep all panels and covers in place when the water muffler system is connected to a power source.
- Insulate yourself from work and ground: wear insulating gloves, shoes and clothing.
- Keep gloves, shoes, clothing, work area, torch, and this machinery dry.



#### **EXPLOSION WILL RESULT IF PRESSURIZED CONTAINERS ARE CUT.**



#### **ARC RAYS CAN INJURE EYES AND BURN SKIN.**

- Wear correct eye and body protection.



#### **NOISE CAN DAMAGE HEARING.**

- Wear correct ear protection.



#### **FUMES AND GASES CAN INJURE YOUR HEALTH.**

- Keep your head out of the fumes.
- Provide ventilation, exhaust at the arc, or both to keep the fumes and gases from your breathing zone and the general area.
- If ventilation is inadequate, use an approved respirator.



#### **HEAT, SPLATTER AND SPARKS CAUSE FIRE AND BURNS.**

- Do not cut near combustible material.
- Do not cut containers that have held combustibles.
- Do not have on your person any combustibles such as a butane lighter or matches.
- Pilot arc can cause burns. Keep the torch nozzle away from yourself and others when the switch is depressed.
- Wear correct eye and body protection.

# SAFETY, INTRODUCTION & SPECIFICATIONS

---

## INTRODUCTION

The Air Injected Water Muffler System is a plasma cutting torch option which greatly improves the HT400 and HT4000/4001 plasma cutting systems safety and pollution control capabilities. This water muffler system can be used to cut both above and below water. The Air Injected Water Muffler System must be used in conjunction with the Water Table Pollution Control System.

### **Above-Water Cutting**

When used above water (material at the water line), the system becomes an effective pollution control attachment which substantially reduces noise levels, ultraviolet radiation, glare, and airborne particulates. Noise levels less than 86 dBA can be expected when cutting with oxygen to a maximum current of 260A. Noise levels less than 90 dBA can be expected when cutting with nitrogen to a maximum current of 400A. In addition, the water muffler improves cut quality by keeping the water table water away from the cut zone and by continuously flushing the back of the workpiece with air, preventing hydrogen from accumulating on the underside.

### **Underwater Cutting**

When used underwater, the water muffler provides a water and air shield which removes water from the cut zone, allowing for optimum operation of the plasma torch. The water muffler greatly improves the quality of the cuts made underwater and allows for cutting at the same speeds as above-water cutting. The continuous flushing of the back of the workpiece with air, prevents hydrogen from accumulating. Underwater operation also provides the maximum possible noise suppression over the widest possible range of current levels. Less than 85 dBA can be expected for both oxygen and nitrogen when cutting three inches or more below the surface of the water.

### **System Components**

Refer to *Installation, Section 2, Upon Receipt*, for a list of the system components.

### **Water Table Requirements**

When cutting above water, the water level in the water table should be up to or slightly above the bottom surface of the workpiece. The water reservoir located beneath the plate prevents the high-intensity sound waves from escaping out from the underside of the workpiece.

When the water muffler is used below water, the water level in the water table must be three inches or more above the top surface of the workpiece.

The water muffler significantly cools the smoke and fumes generated by plasma cutting (especially when cutting underwater). Proper ventilation and fume extraction near the surface of the water table is required.

# SAFETY, INTRODUCTION & SPECIFICATIONS

---

## SPECIFICATIONS

### **Air Control Box (# 028298)**

Input Power .....	120 VAC
Input Air Pressure .....	80 -120 psi (5.5-8.3 bar) @ 20 scfm (566 l/m) minimum
Weight .....	6 lbs. (2.7 kg)
Dimensions .....	6-1/4" (159mm) (H) x 6-1/4" (159mm) (W) x 4-1/4" (108mm) (D)

### **Pump\* (# 031006, # 031088, # 031089)**

Input Power:

# 031006 .....	Pump (3/4 DL) assembly with motor, 2 HP, 3500 RPM 230/460, 3 PH, 60 Hz
# 031088 .....	Pump (3/4 DL) assembly with motor, 2 HP, 3500 RPM 380-415V, 3 PH, 50 Hz
# 031089 .....	Pump (3/4 DL) assembly with motor, 2 HP, 3500 RPM 575V, 3 PH, 60 Hz

Maximum Working Pressure .....	100 psig (6.9 bar)
Duty .....	Continuous
Direction of Rotation .....	Clockwise (viewed from motor end)
Output .....	18-20 GPM
Weight .....	85 lbs. (38.6 kg) (includes base and pump contactor box)
Dimensions .....	19" (482mm) (H) x 11" (279mm) (W) x 17" (432mm) (D) (includes base and pump contactor box)

\* Refer to the Appendix for additional pump specifications.

### **Pump Contactor (# 003017)**

Contactor .....	Size 00, 120 VAC Coil
-----------------	-----------------------

## Section 2 Installation

In this section:

---

Upon Receipt .....	2-2
Damage Claims .....	2-2
Installation .....	2-3
Install Nozzle Assembly .....	2-3
Install Pump .....	2-3
Install Air Control Box .....	2-5
Installation Checkout .....	2-9
Pump Discharge Hose Water Recovery Checkout .....	2-9
Install Check Valve .....	2-10

---

# INSTALLATION

---

## UPON RECEIPT

1. Remove the Air Injected Water Muffler System and save the carton. The carton is reusable and provides an impact-resistant box for transporting or storing the system and parts. The carton should contain one of the following systems:

034126 Water Muffler System 230/460V, 3 PH, 60 Hz w/Hoses

034127 Water Muffler System 230/460V, 3 PH, 60 Hz w/o Hoses

034128 Water Muffler System 380/415V, 3 PH, 60 Hz w/Hoses

034129 Water Muffler System 380/415V, 3 PH, 60 Hz w/o Hoses

034130 Water Muffler System 575V, 3 PH, 60 Hz w/Hoses

034131 Water Muffler System 575V, 3 PH, 60 Hz w/o Hoses

Refer to *Parts List, Section 4*, for a list of components which make up the systems listed above.

2. Verify that all components are present. Alert your distributor if any parts are missing.
3. Inspect the water muffler components for any physical damage that may have occurred during shipping. If there is evidence of damage, see the *Damage Claims* section below.

Before operating the water muffler system, read the *Safety* and *Operation* sections of this manual.

## DAMAGE CLAIMS

**Claims for damage during shipment** - If any of the components were damaged during shipment, you must file a claim with the carrier. Hypertherm will furnish you with a bill of lading upon request. Call Customer Service at 1-800-643-0030.

## **INSTALLATION**

To install the Air Injected Water Muffler System, you need to install and interconnect the following units:

- Nozzle Assembly
- Pump Unit
- Air Control Box

### **Install Nozzle Assembly**

The torch should be installed onto the cutting machine prior to installing the nozzle assembly. If the torch has not been installed, refer to the applicable instruction manual to do so.

Note: The nozzle assembly (# 034114 or # 034118) can be mounted onto the torch with the water muffler retaining cap (# 020579) and consumables in place. Prior to mounting the nozzle assembly, check the consumables (nozzle, swirl ring, and electrode) and replace if necessary. Refer to the applicable instruction manual for detailed information.

To install the nozzle assembly, refer to Figure 2-1 and proceed with following procedure.

1. Ensure the O-rings inside the nozzle assembly have been lightly coated with silicone lubricant. Note that the water sleeve (# 034115) is already mounted in the nozzle assembly.
2. Slide the nozzle assembly onto the torch and position the upper edge of the nozzle assembly flush with where the torch and torch insulating sleeve meet. Secure nozzle assembly to torch main body with clamping screw.
3. Slide the air deflector sleeve (# 034116) up inside the water sleeve until it seats.

### **Install Pump**

The pump should be installed by an experienced electrician in compliance with national/international electrical codes. Depending on the input power requirements, pump motors are rated at 230/460 VAC, 3 phase, 60 Hz; 380/415 VAC, 3 phase, 50 Hz; and 575 VAC, 3 phase, 60 Hz. The pump motors are provided with overload protection. The 230/460 VAC pumps are shipped from the factory wired for 460 VAC. If 230 VAC operation is required, refer to the data tag on the pump to wire the motor for 230 VAC operation. The wires are located in the box which next to the data tag.

To install and connect the pump, refer to Figures 2-2 and 2-3 and proceed as follows:

1. Place the pump within four feet (1.2 m) of the water table feed port to be used, if hose is to be used. Longer hose distances can result in pump priming and water

# INSTALLATION

---

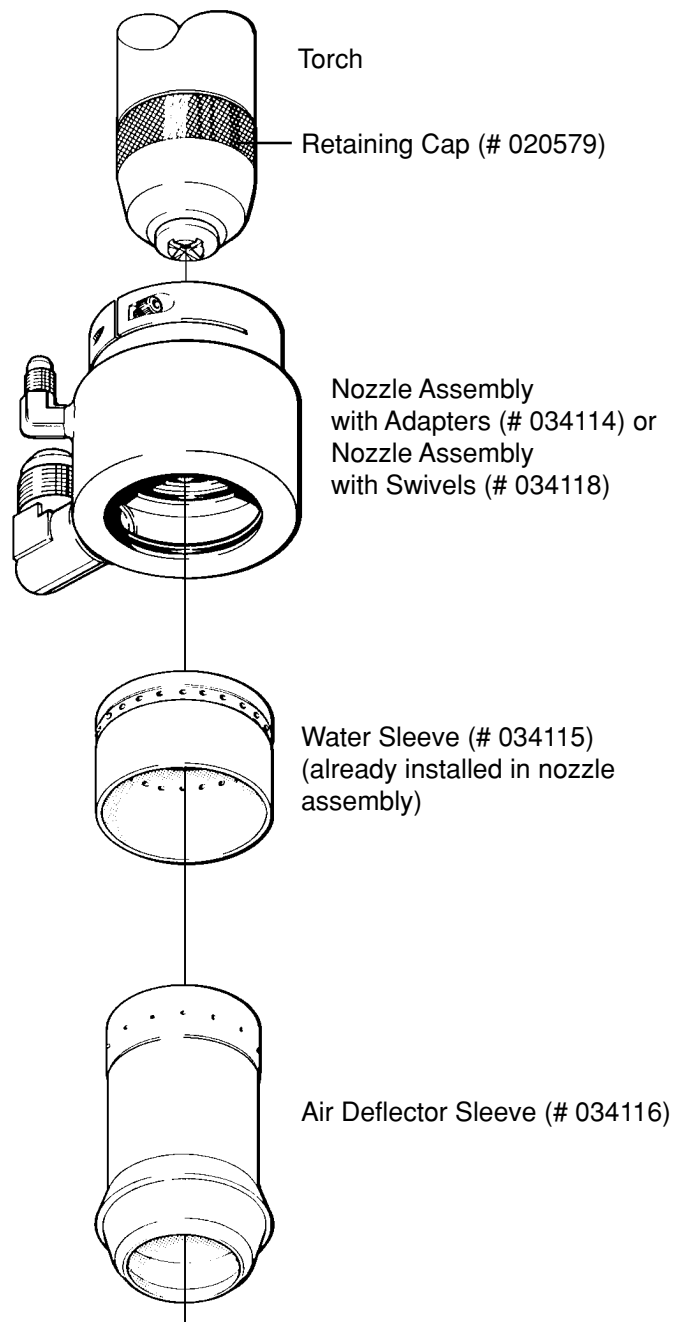

Figure 2-1 Nozzle Assembly with Water Sleeve and Air Deflector Sleeve Installation

# INSTALLATION

lag problems during startup, resulting in excessive noise and smoke during initial starting. If more than four feet (1.2 m) of hose is required, it is recommended that solid tubing be used up to a maximum length of eight feet (2.4 m). If solid tubing is to be installed, **do not use teflon tape**. Use liquid pipe-thread sealant only.

The pump must be below the water level of the water table in order to function properly.

2. Install the suction filter/strainer (# 027009) to the water table feed port. Figure 2-2 represents an optional installation; the user may wish to use another configuration. The reducer bushing (# 015578) and nipple (# 015509) are supplied; other required filter/strainer connection and support hardware are customer supplied.
3. Connect the pump inlet to the filter/strainer assembly using the supplied four-foot hose assembly (# 024023) or solid tubing (eight feet [2.4 m] maximum). See Figure 2-3.
4. Route the pump discharge hose assembly (# 024022) from the pump to the nozzle assembly through the power track or festoon system. In no case should the discharge hose be longer than 80 feet (24.4 m).

Note: If the discharge hose is routed in an overhead festoon system, a check valve may be required. To determine if a check valve is needed, refer to the *Pump Discharge Hose Water Recovery Checkout* at the back of this section.

5. Connect three-conductor cable (# 023445, 50 ft. [15.3 m]) to the water muffler pump contactor (AC and ground). Refer to Water Muffler/Pump Cable table below.
6. Connect the plug end of the cable to the receptacle on the rear of the power supply labeled W-M PUMP.

**Water Muffler/Pump Cable**

From Power Supply W-M Pump Recp/Plug	To W-M Pump Contactor	Color	Function
2	Coil	Black	W-M Coil
4	AC Neutral	White	AC Neutral
3	Ground	Green	Ground

## Install Air Control Box

1. Mount the air control box to a convenient location on the cutting machine, so that it is no farther than 10 feet (3 m) from the W-M nozzle assembly.

# INSTALLATION

---

2. Route the AIR OUT hose assembly (# 024022) from the air control box to the nozzle assembly through the power track or festoon system. In no case should the discharge hose be longer than 10 feet (3 m). See Figure 2-3.
3. Route the air supply hose assembly from the shop air supply to the AIR IN fitting on the air control box. The shop air supply must be clean, dry and oil free. It is mandatory that the air supply be oil free, especially when using oxygen as the plasma gas. The air supply must meet the following pressures and flow rate:
  - 80 -120 psi (5.5-8.3 bar) delivery pressure
  - 20 scfm (566 l/m) minimum flow rate
4. Route the five-conductor cable from the air control box to the receptacle on the rear of the power supply labeled W-M AIR. See Figure 2-3. Refer to Power Supply/Air Control Box Cable table below.

**Power Supply/Air Control Box Cable**

From Power Supply W-M Air Recp/Plug	To Air Control Box Recp/Plug	Color	Function
11	1	White	W-M Hot
12	2	Black	AC Neutral
13	3	Red	Contactor Coil
14	4	Brown	W-M Coil
6	5	Green	Ground

Cable Part No.	Length (ft./m)
023444	50/15.3
023624	25/7.6
023625	75/23
023626	100/30.5
023627	150/46
023628	200/61

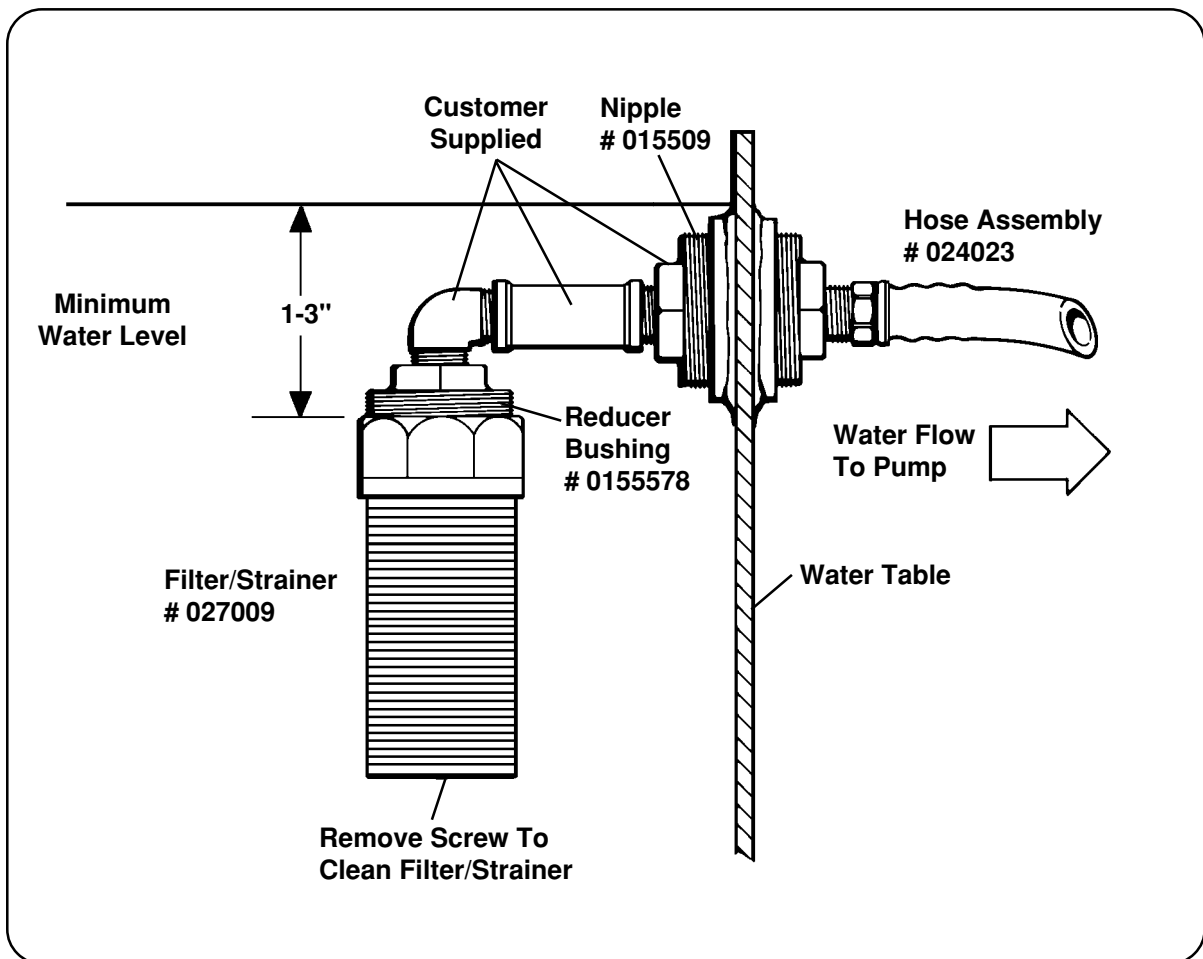

Figure 2-2 Filter/Strainer, Optional Installation

# INSTALLATION

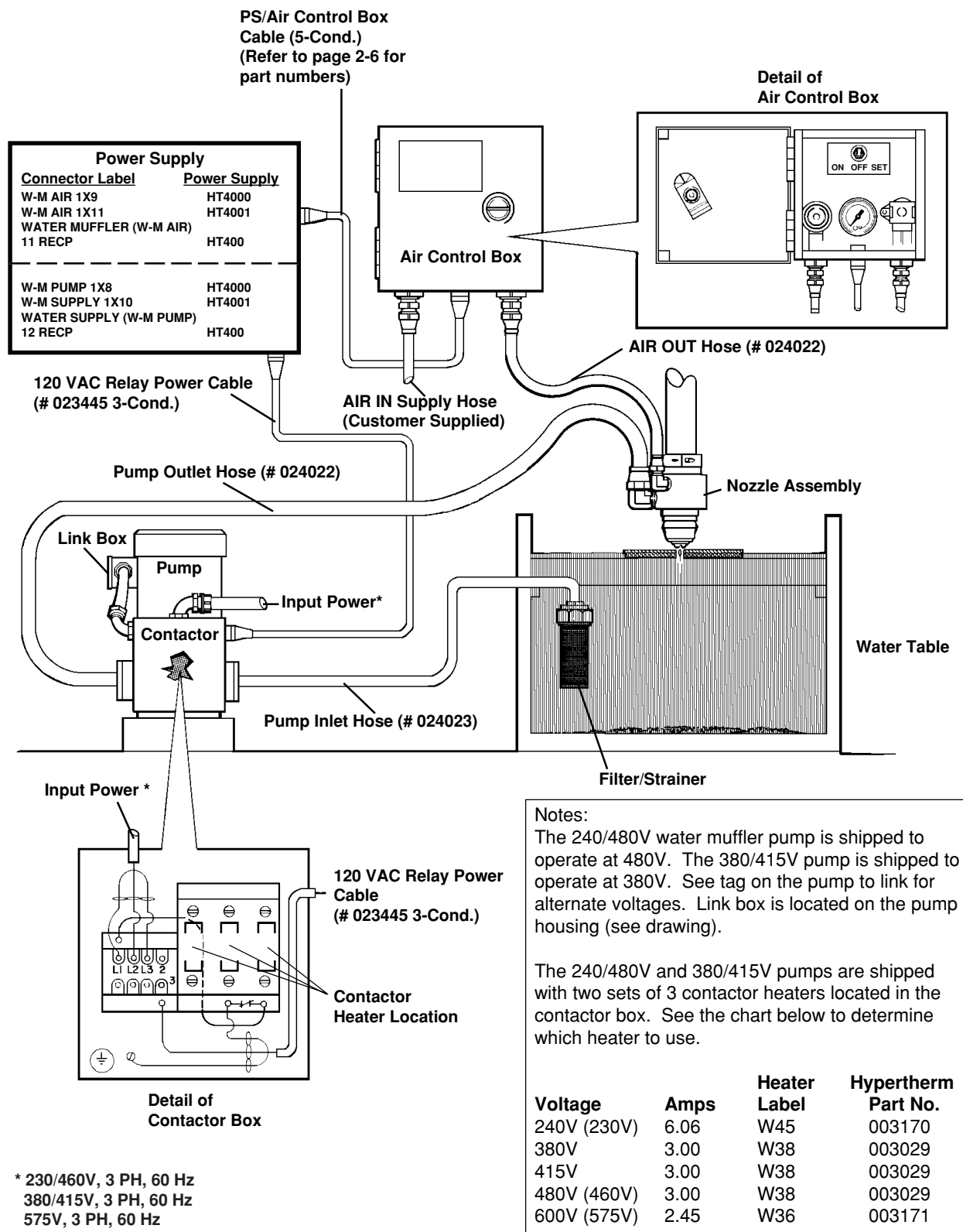

Figure 2-3 Air Injected Water Muffler System Interconnection Diagram

## Installation Checkout

After all power, air and water connections have been completed, test the Air Injected Water Muffler System:

1. Ensure that the water table water level is high enough to feed the pump (covers the filter intake completely).
2. Apply primary power to the power supply.
3. Apply shop air to the air control box. Inside the box, ensure the ON/OFF/SET switch is to OFF.
4. Depress the green POWER ON switch to turn on the power supply.
5. In the air control box, momentarily position the ON/OFF/SET switch to SET and then back to OFF.

Look for a clockwise pump rotation as viewed from the top of the motor. A direction of rotation arrow is also shown on the side of the pump casing. If the pump rotates in a counterclockwise direction, reverse any two of the 3-phase power leads to the motor.

<p><b>Caution: Operating the pump in reverse rotation will cause extensive damage.</b></p>
--

6. Inside the air control box, position the ON/OFF/SET switch to SET. With water and air flowing, check the pressure gauge for 17 psig (1.2 bar) for above-water cutting or 30 psig (2.0 bar) for underwater cutting. Adjust the pressure regulator, if required.
7. Check for an even flow of water around the torch and for leaks around all connections. Tighten connections as necessary. The water pump should deliver approximately 18 to 20 gallons per minute.
8. Readjust the air pressure as performed in step 6, if required.
9. Position the ON/OFF/SET switch to ON. The system is now operational.

## Pump Discharge Hose Water Recovery Checkout

If the pump discharge hose is routed through an overhead festoon system, a check valve may be required. This can be determined by checking to see if the water from the pump discharge hose drains back through the pump when the water muffler system shuts off, and when the water muffler system restarts, the water does not obtain full flow back to the water muffler before the plasma arc fires. If this condition occurs, a check valve needs to be installed according to the procedure that follows.

# INSTALLATION

---

## Install Check Valve

Parts required:

- Valve, check, # 034156
- Gland, hose 3/4 NPT X #12 straight (2), # 015052
- Clamp, hose 3/4 - 1-3/4 (2), # 015234

Install the check valve in-line on the pump discharge hose as follows:

1. Cut the pump discharge hose (Fig 2-3) as close to the nozzle assembly as possible to install the check valve. (The check valve should not be installed farther than 6 feet (1.8 m) from the nozzle assembly.)
2. Apply liquid pipe sealant on to the threads of both glands. Screw glands into the ends of the check valve and tighten with wrench.
3. Slide the hose clamps over the ends of the discharge hose. Then slide each end of the hose over the ends of the check valve. Slide the hose clamps over the ends of the check valve and tighten. (The arrow on the check valve indicates the direction of water flow and should point in the direction of the nozzle assembly.)
4. Perform the *Installation Checkout* again to ensure proper water muffler operation.

## Section 3 Operation & Maintenance

In this section:

---

Operation .....	3-2
Daily Setup and Operation .....	3-2
Above-Water Cutting .....	3-2
Underwater Cutting .....	3-3
Maintenance .....	3-3
Nozzle Assembly .....	3-3
Pump Unit .....	3-4
Filter/Strainer .....	3-4
Pump Contactor .....	3-4
Air Control Box & Pump Contactor 120 VAC Control Signals .....	3-4
Technical Questions .....	3-4

---

# OPERATION & MAINTENANCE

---

## OPERATION

The Air Injection Water Muffler System will start automatically with the initiation of the start signal to the plasma cutting torch. The pump contactor coil and air solenoid valve are energized simultaneously by a 120 VAC signal routed through the ON/OFF/SET switch in the air control box from the power supply.

- When the switch is in the ON position, the 120 VAC signal will be supplied to the pump contactor and air solenoid valve when the power supply main contactor is activated.
- When the switch is in the SET position, the 120 VAC signal will be supplied to the pump contactor and air solenoid valve. In this position, the air pressure values are set. The power supply main contactor is not activated at this time.
- When the switch is in the OFF position, the water muffler system is disabled.

The operating procedures and requirements for above and underwater cutting are as follows:

### **Daily Setup and Operation**

1. Apply primary power to the power supply.
2. Apply shop air to the air control box. Inside the box, ensure the ON/OFF/SET switch is to OFF.
3. Depress the green POWER ON switch to turn on the power supply.
4. Inside the air control box, position the ON/OFF/SET switch to SET. With water and air flowing, check the pressure gauge for 17 psig @ 10 scfm (1.2 bar @ 283 l/m) for above- water cutting or 30 psig @ 20 scfm (2.0 bar @ 566 l/m) for underwater cutting. Adjust the pressure regulator, if required.
5. Check for an even flow of water around the torch and for leaks around all connections. Tighten connections as necessary. The water pump should deliver approximately 18 to 20 gallons per minute.
6. Recheck the air pressure as performed in step 4, if required.
7. Position the ON/OFF/SET switch to ON. The system is now operational.

### **Above-Water Cutting**

At the water table, ensure the water level is maintained at or slightly above the bottom of the workpiece. Due to water muffler system pressure drops, the pressure setting of 17 psig (1.2 bar) may be insufficient to supply the 10 scfm (283 l/m) flowrate. If this is the case, increase the pressure until the proper flowrate has been achieved.

If initial height sensing (IHS) is not used, manual torch positioning will be necessary.

# OPERATION & MAINTENANCE

---

This is done by lowering the torch to approximately 1/4-inch (6mm) above the top surface of the workpiece.

## Underwater Cutting

At the water table, ensure the water level is maintained at three inches or more above the top surface of the workpiece. Due to water muffler system pressure drops, the pressure setting of 30 psig (2.0 bar) may be insufficient to supply the 20 scfm (566 l/m) flowrate. If this is the case, increase the pressure until the proper flowrate has been achieved.

It is recommended that initial height sensing (IHS) be used when cutting under water. If IHS is not used, manually position the torch as in above-water cutting.

## MAINTENANCE

To maintain the Air Injected Water Muffler System, periodically inspect, clean, and replace components as required. In the event the system does not work properly, determine if the problem is air pressure, water pressure or if one or both of the 120 VAC control signals are missing.

## Nozzle Assembly

To inspect and clean the nozzle assembly, refer to Figure 2-1 and proceed as follows:

1. Loosen the clamping screw securing the nozzle assembly or to the torch.
2. Pull the nozzle assembly (# 034114 or # 034118) with air deflector sleeve (# 034116) and water sleeve (# 034115) off of torch.
3. Grasp the air deflector sleeve and simultaneously twist and pull to remove. With a cloth wipe the bottom, sides and inside of sleeve.
4. Grasp the water sleeve and simultaneously twist and pull to remove. With a cloth wipe the sides and inside of sleeve.
5. Apply a small amount of silicone grease to the O-rings inside the nozzle assembly.
6. Slide the nozzle assembly onto the torch and position the upper edge of the nozzle assembly flush with where the torch and torch insulating sleeve meet. Secure nozzle assembly to torch main body with clamping screw.
7. Slide the water sleeve hole end first, up into the nozzle assembly until it seats.
8. Prior to positioning the air deflector sleeve check the consumables (nozzle, swirl ring, and electrode) and replace if necessary. Refer to the applicable instruction manual for detailed information.
9. Slide the air deflector sleeve up inside the water sleeve until it seats.

# OPERATION & MAINTENANCE

---

## Pump Unit

If the pump is faulty and requires maintenance, refer to the maintenance instructions for the water muffler pump in the Appendix at the back of this manual. Pump maintenance also includes inspecting all hoses and connections and replacing as needed. The suction filter/strainer should also be checked and cleaned periodically.

## Filter/Strainer

The pump with 50 feet of 3/4-inch (15.3 m of 19mm) ID hose and the W-M nozzle assembly should produce a flow of approximately 20 gallons per minute. A flow lower than 18 gallons per minute reduces water muffler effectiveness. If this situation occurs clean the filter/strainer in the water table.

To clean the suction filter/strainer, remove the screw and the plastic cover at the bottom. See Figure 2-2. After cleaning the filter/strainer, replace the cover and screw it back on.

## Pump Contactor

If the pump contactor or 120 VAC relay coil is defective, contact an experienced electrician to perform the maintenance.

## Air Control Box & Pump Contactor 120 VAC Control Signals

If the 120 VAC control signal to air control box and/or pump contactor is missing, refer to *Installation*, Section 2, Figure 2-3 and the wiring diagram of the applicable instruction manual for the missing control signals.

## TECHNICAL QUESTIONS

If you are unable to solve a problem after reviewing this manual, the applicable instruction manual, and wiring diagram:

- Call your distributor. They will be able to help you, or refer you to an authorized Hypertherm repair facility.
- If you need additional assistance, call our Field Service group at 1-800-643-9878.

## Section 4 Parts List

In this section:

---

Water Muffler Systems .....	4-2
230/460V, 3 Ph, 60 Hz w/Hoses .....	4-2
230/460V, 3 Ph, 60 Hz w/o Hoses .....	4-2
380-415V, 3 Ph, 50 Hz w/Hoses .....	4-3
380-415V, 3 Ph, 50 Hz w/o Hoses .....	4-3
575V, 3 Ph, 60 Hz w/Hoses .....	4-4
575V, 3 Ph, 60 Hz w/o Hoses .....	4-4
Nozzle Assembly with Adapters .....	4-5
Nozzle Assembly with Swivels .....	4-6
Water Supply Assembly .....	4-7
Pump Assembly .....	4-9
Pump Discharge Hose Check Valve (Optional) .....	4-9

---

# PARTS LIST

---

## WATER MUFFLER SYSTEMS

### 230/460V, 3 Ph, 60 Hz w/Hoses (# 034126)

<u>Part Number</u>	<u>Description</u>	<u>Quantity</u>
024022	Hose assembly, #12 x 50 ft. with:	1
015262	Swivel, #12 3/4 Syn hose Brs (attached to hose)	2
015264	Ferrule, 1.150 ID x .88 Brs (attached to hose)	2
024023	Hose assembly, #12 x 4 ft. with:	1
015262	Swivel, #12 3/4 Syn hose Brs (attached to hose)	1
015264	Ferrule, 1.150 ID x .88 Brs (attached to hose)	1
015052	Adapter, 3/4 NPT x #12 (attached to hose)	1
027009	Filter, 2" NPT, water	1
015578	Reducer bushing, 2" x 3/4", galv	1
015509	Nipple 2" x CL, galv	1
027055	Silicone lubricant	1
025031	O-ring kit	1
008212	Strain relief, 1/2 NPT X .197 -.354	2
015012	Adapter, 1/4 NPT x # 6	1
015013	Swivel, # 6	4
023444	Cable, W-M air control, 50 ft.	1
023445	Cable, W-M pump contactor, 50 ft.	1
028298	Air control box	1
028042	Water supply, W-M (refer to page 4-7)	1
034114*	Nozzle assembly, W-M, with adapters (refer to page 4-5)	1
034118*	Nozzle assembly, W-M, with swivels (refer to page 4-6)	1
020579	Cap, HT400/PAC170 taper nozzle retaining	1
046016	Hose, 3/8" ID Blk	60 ft.

### 230/460V, 3 Ph, 60 Hz w/o Hoses (# 034127)

<u>Part Number</u>	<u>Description</u>	<u>Quantity</u>
015262	Swivel, #12 3/4 Syn hose Brs	3
015264	Ferrule, 1.150 ID x .88 Brs	3
015052	Adapter, 3/4 NPT x #12	1
015578	Reducer bushing, 2" x 3/4", galv	1
015509	Nipple 2" x CL, galv	1
027009	Filter, 2" NPT, water	1
027055	Silicone lubricant	1
025031	O-ring kit	1
008212	Strain relief, 1/2 NPT X .197 -.354	2
015012	Adapter, 1/4 NPT x # 6	1
015013	Swivel, # 6	4
023444	Cable, W-M air control, 50 ft.	1
023445	Cable, W-M pump contactor, 50 ft.	1
028298	Air control box	1
028042	Water supply, W-M (refer to page 4-7)	1
034114*	Nozzle assembly, W-M, with adapters (refer to page 4-5)	1
034118*	Nozzle assembly, W-M, with swivels (refer to page 4-6)	1
020579	Cap, HT400/PAC170 taper nozzle retaining	1

\* The water muffler systems come with either the 034114 or 034118 nozzle assembly.

# PARTS LIST

## 380-415V, 3 PH, 50 Hz w/Hoses (# 034128)

<u>Part Number</u>	<u>Description</u>	<u>Quantity</u>
024022	Hose assembly, #12 x 50 ft. with:	1
015262	Swivel, #12 3/4 Syn hose Brs (attached to hose)	2
015264	Ferrule, 1.150 ID x .88 Brs (attached to hose)	2
024023	Hose assembly, #12 x 4 ft. with:	1
015262	Swivel, #12 3/4 Syn hose Brs (attached to hose)	1
015264	Ferrule, 1.150 ID x .88 Brs (attached to hose)	1
015052	Adapter, 3/4 NPT x #12 (attached to hose)	1
027009	Filter, 2" NPT, water	1
015578	Reducer bushing, 2" x 3/4", galv	1
015509	Nipple 2" x CL, galv	1
027055	Silicone lubricant	1
025031	O-ring kit	1
008212	Strain relief, 1/2 NPT X .197 -.354	2
015012	Adapter, 1/4 NPT x # 6	1
015013	Swivel, # 6	4
023444	Cable, W-M air control, 50 ft.	1
023445	Cable, W-M pump contactor, 50 ft.	1
028298	Air control box	1
028299	Water supply, W-M (refer to page 4-7)	1
034114*	Nozzle assembly, W-M, with adapters (refer to page 4-5)	1
034118*	Nozzle assembly, W-M, with swivels (refer to page 4-6)	1
020579	Cap, HT400/PAC170 taper nozzle retaining	1
046016	Hose, 3/8" ID Blk	60 ft.

## 380-415V, 3 PH, 50 Hz w/o Hoses (# 034129)

<u>Part Number</u>	<u>Description</u>	<u>Quantity</u>
015262	Swivel, #12 3/4 Syn hose Brs	3
015264	Ferrule, 1.150 ID x .88 Brs	3
015052	Adapter, 3/4 NPT x #12	1
015578	Reducer bushing, 2" x 3/4", galv	1
015509	Nipple 2" x CL, galv	1
027009	Filter, 2" NPT, water	1
027055	Silicone lubricant	1
025031	O-ring kit	1
008212	Strain relief, 1/2 NPT X .197 -.354	2
015012	Adapter, 1/4 NPT x # 6	1
015013	Swivel, # 6	4
023444	Cable, W-M air control, 50 ft.	1
023445	Cable, W-M pump contactor, 50 ft.	1
028298	Air control box	1
028299	Water supply, W-M (refer to page 4-7)	1
034114*	Nozzle assembly, W-M, with adapters (refer to page 4-5)	1
034118*	Nozzle assembly, W-M, with swivels (refer to page 4-6)	1
020579	Cap, HT400/PAC170 taper nozzle retaining	1

\* The water muffler systems come with either the 034114 or 034118 nozzle assembly.

# PARTS LIST

---

## 575V, 3 Ph, 60 Hz w/Hoses (# 034130)

<u>Part Number</u>	<u>Description</u>	<u>Quantity</u>
024022	Hose assembly, #12 x 50 ft. with:	1
015262	Swivel, #12 3/4 Syn hose Brs (attached to hose)	2
015264	Ferrule, 1.150 ID x .88 Brs (attached to hose)	2
024023	Hose assembly, #12 x 4 ft. with:	1
015262	Swivel, #12 3/4 Syn hose Brs (attached to hose)	1
015264	Ferrule, 1.150 ID x .88 Brs (attached to hose)	1
015052	Adapter, 3/4 NPT x #12 (attached to hose)	1
027009	Filter, 2" NPT, water	1
015578	Reducer bushing, 2" x 3/4", galv	1
015509	Nipple 2" x CL, galv	1
027055	Silicone lubricant	1
025031	O-ring kit	1
008212	Strain relief, 1/2 NPT X .197 -.354	2
015012	Adapter, 1/4 NPT x # 6	1
015013	Swivel, # 6	4
023444	Cable, W-M air control, 50 ft.	1
023445	Cable, W-M pump contactor, 50 ft.	1
028298	Air control box	1
028308	Water supply, W-M (refer to page 4-7)	1
034114*	Nozzle assembly, W-M, with adapters (refer to page 4-5)	1
034118*	Nozzle assembly, W-M, with swivels (refer to page 4-6)	1
020579	Cap, HT400/PAC170 taper nozzle retaining	1
046016	Hose, 3/8" ID Blk	60 ft.

## 575V, 3 Ph, 60 Hz w/o Hoses (# 034131)

<u>Part Number</u>	<u>Description</u>	<u>Quantity</u>
015262	Swivel, #12 3/4 Syn hose Brs	3
015264	Ferrule, 1.150 ID x .88 Brs	3
015052	Adapter, 3/4 NPT x #12	1
015578	Reducer bushing, 2" x 3/4", galv	1
015509	Nipple 2" x CL, galv	1
027009	Filter, 2" NPT, water	1
027055	Silicone lubricant	1
025031	O-ring kit	1
008212	Strain relief, 1/2 NPT X .197 -.354	2
015012	Adapter, 1/4 NPT x # 6	1
015013	Swivel, # 6	4
023444	Cable, W-M air control, 50 ft.	1
023445	Cable, W-M pump contactor, 50 ft.	1
028298	Air control box	1
028308	Water supply, W-M (refer to page 4-7)	1
034114*	Nozzle assembly, W-M, with adapters (refer to page 4-5)	1
034118*	Nozzle assembly, W-M, with swivels (refer to page 4-6)	1
020579	Cap, HT400/PAC170 taper nozzle retaining	1

\* The water muffler systems come with either the 034114 or 034118 nozzle assembly.

## NOZZLE ASSEMBLY WITH ADAPTERS

Part No. - 034114

<u>Part Number</u>	<u>Description</u>	<u>Quantity</u>
034114	Nozzle assembly with adapters	1
034115	Water sleeve	1
034116	Air deflector sleeve	1
044036	O-ring	2
044139	O-ring	2
044226	O-ring	1

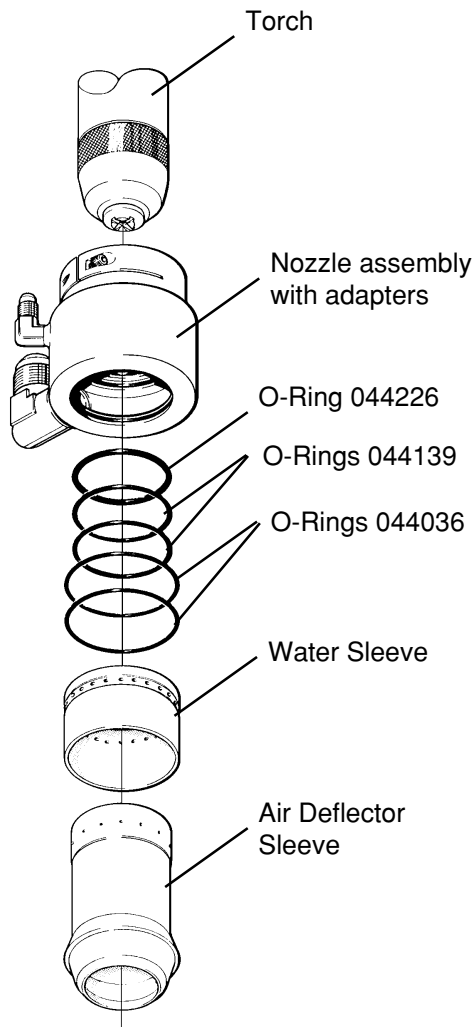

Figure 4-1 Nozzle Assembly with Adapters

# PARTS LIST

---

## NOZZLE ASSEMBLY WITH SWIVELS

Part No. - 034118

<u>Part Number</u>	<u>Description</u>	<u>Quantity</u>
034118	Nozzle assembly with swivels	1
034115	Water sleeve	1
034116	Air deflector sleeve	1
044036	O-ring	2
044139	O-ring	2
044226	O-ring	1

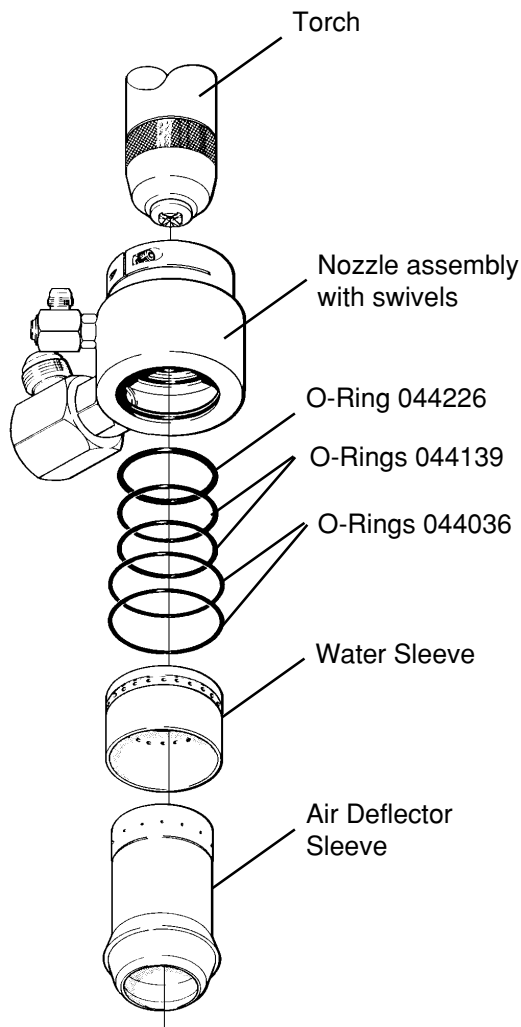

Figure 4-2 Nozzle Assembly with Swivels

# PARTS LIST

## WATER SUPPLY ASSEMBLY (FIG 4-3)

Stock No. - 028042 — 240/480V, 3PH, 60 HZ

Stock No. - 028299 — 380-415V, 3PH, 50 Hz

<u>Stock Number</u>	<u>Description</u>	<u>Item</u>	<u>Quantity</u>
031006	Pump (3/4 DL) assembly with motor, 2 HP,	1	1
or	3500 RPM 230-460 VAC, 3 phase		
031088	Pump (3/4DL) assembly with motor, 2 HP,	1	1
	3500 RPM 380-415 VAC, 3 phase		
015051	Adapter, 3/4 NPT x #12	2	2
004437	Base, water supply W-M	3	1
008045	Fitting, conduit elbow, 1/2 x 1/2	4	1
008047	Strain relief, 1/2 x .250-.375	5	1
003017	Contactor, size 00,120 VAC coil;	6	1
003029	Heater:003017 Cntor 3.00A -W38		3
003170	Heater:003017 Cntor 6.06A -W45		3
034006	Contactor mounting bracket	7	1
046011	Conduit,1/2" sealtite flexible	8	6 "
008044	Fitting, conduit straight, 1/2 x 1/2	9	1

Stock No. - 028308 — 600V, 3PH, 60 Hz

<u>Stock Number</u>	<u>Description</u>	<u>Item</u>	<u>Quantity</u>
031089	Pump (3/4 DL) assembly with motor, 2 HP,	1	1
	3500 RPM 575 VAC, 3 phase		
015051	Adapter, 3/4 NPT x #12	2	2
004437	Base, water supply W-M	3	1
008045	Fitting, conduit elbow, 1/2 x 1/2	4	1
008047	Strain relief, 1/2 x .250-.375	5	1
003017	Contactor, size 00,120 VAC coil;	6	1
003171	Heater:003017 Cntor 2.45A -W36		3
034006	Contactor mounting bracket	7	1
046011	Conduit,1/2" sealtite flexible	8	6 "
008044	Fitting, conduit straight, 1/2 x 1/2	9	1

# PARTS LIST

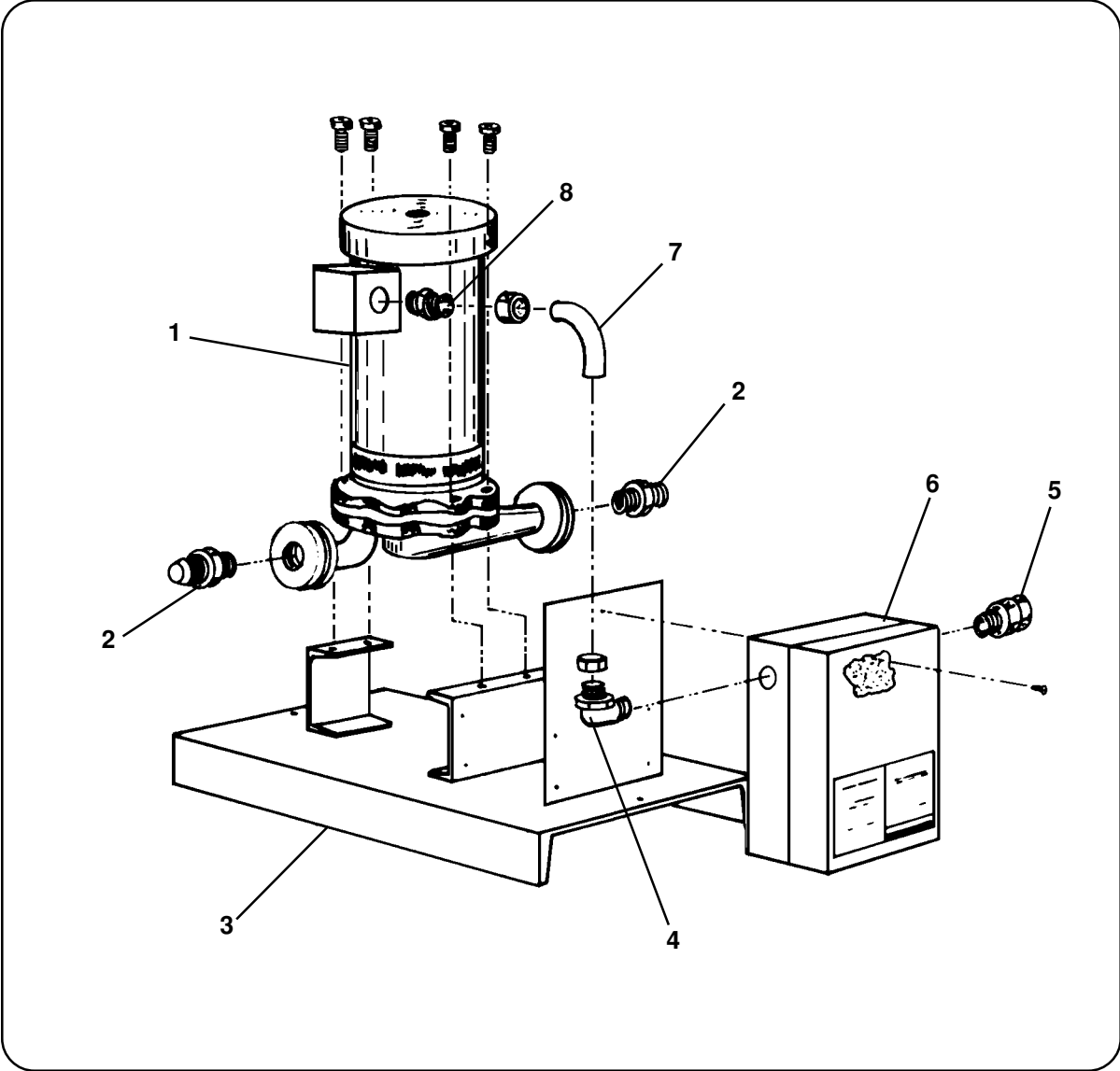

Figure 4-3 Water Supply Assembly

# PARTS LIST

## PUMP ASSEMBLY (SEE APPENDIX)

Part No. - 031049

<u>Part Number</u>	<u>Description</u>	<u>Item</u>	<u>Quantity</u>
031036	Impeller, 1285505	3	1
031047	Casing, 1326505	5	1
*	Casing cap screw	5D	8
031035	Adapter cradle, 1250705	7	1
*	Adapter Cap Screws	7G	1
031048	Backhead, 1080280	22	1
031040	Clearance shim, 9157206-7-8	37	3
031041	Casing gasket, 9155333	77	1
031042	Stationary seal element, 6960440	95A	1
	Rotating seal face, 6960440	95B	1

\* Obtain locally

## PUMP DISCHARGE HOSE CHECK VALVE (OPTIONAL)\*

<u>Part Number</u>	<u>Description</u>	<u>Quantity</u>
034156	Valve, check	1
015052	Gland, hose 3/4 NPT x #12 straight	2
015234	Clamp, hose 3/4 to 1-3/4 inch	2

\* Refer to Section 2, *Installation* for pump discharge hose water recovery checkout and check valve installation information.

## APPENDIX

In this section:

---

Water Muffler Pumps ..... a-2

---



# *DEAN BROTHERS PUMPS*

**INSTALLATION  
OPERATION  
AND  
MAINTENANCE  
MANUAL**

*DeanLine*  
**SERIES**

**DO NOT OPERATE PUMP BEFORE  
READING THIS MANUAL**

*ESTABLISHED 1869*  
**DEAN BROTHERS PUMPS INC.**  
*INDIANAPOLIS INDIANA, 46268*  
*P.O. Box 68172*

THE BEST IS OUR STANDARD



**MECHANICAL DESIGN SPECIFICATIONS**

Direction of Rotation ..... Clockwise (viewed from motor end).  
 Driver Rating ..... 230/460 Volt, 3 Phase, 60 Cycle, NEMA C  
 Flange, #56J Frame, Dean Standard  
 Motor, 304ss Shaft with standard shaft  
 extension for jet motor. NEMA T3B  
 temperature rating for Ex.Pr. motors. Ex.  
 Pr. motors are Class I, Group D; Class II,  
 Groups F & G.  
 @ 1750 RPM ..... ½ HP.  
 @ 3500 RPM ..... 1, 1½, and 2 HP.  
 @ RPM for Air Motor ..... 100 PSI air 4 HP @ 3000 RPM.  
 Flanges ANSI Rating ..... 125 Lb. Cast Iron (Deanalloy 20); 150 Lb.  
 316 ss (Deanalloy 50).  
 Impeller ..... Mechanically and Electrically  
 Balanced.  
 Maximum Working Pressure ..... 100 PSIG.  
 Maximum Suction Pressure ..... Any part of Working Pressure.  
 Hydrostatic Test Pressure ..... 150 PSIG Cast Iron (Deanalloy 20); 200  
 PSIG 316ss (Deanalloy 50).  
 Pumping Temperature  
 Minimum ..... Minus 20°F Cast Iron (Deanalloy 20) and  
 316ss (Deanalloy 50).  
 Maximum ..... 220°F Cast Iron (Deanalloy 20) and  
 316ss (Deanalloy 50).  
 Stuffing Box ..... Integral Mechanical Seal only, internal  
 seal face flushing all pumps.

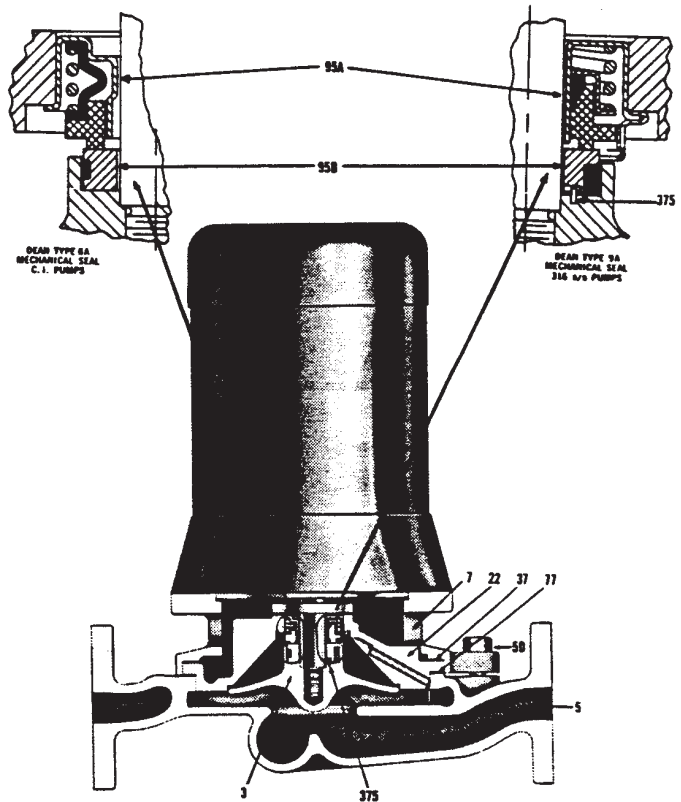

**MECHANICAL SEAL SPECIFICATIONS**

**STANDARD MATERIALS OF CONSTRUCTION**

PART NO.	PART NAME	CLASS 20	CLASS 50
3	Impeller	C.I.	316ss
5	Casing	C.I.	316ss
5D	Casing Cap Screw	1020 Stl.	302ss
7	Adapter Cradle	C.I.	C.I.
7G	Adapter Cap Screws	1020 Stl.	1020 Stl.
22	Backhead	C.I.	316ss
37	Clearance Shim	Plastic	Plastic
77	Casing Gasket	Asbestos	Asbestos
95A	Stationary Seal Element Stationary Face Spring Holder Shaft Packing	Carbon 304ss Viton	Carbon 316ss 316ss Teflon
95B	Rotating Seal Face	Ceramic	Ceramic
375	Seal Dowel Pin	Not Required	316ss

PUMP MAT'L	MECHANICAL SEAL	SUCTION PRESSURE		TEMPERATURE	
CLASS		MAX.	MIN.	MAX.	MIN.
20 or 50	Dean Type 6A, 6C or 9A	100 PSIG	2 PSIA	220°F	-20°F

**AIR MOTOR OPTION**

For best performance and life of the air motor, we offer the following suggestions and accessories.

- The exhaust silencer provided at no charge with the pump can impose sufficient back pressure so as to require as much as twenty psi additional inlet pressure. To eliminate this back pressure, we offer a muffler.
- The speed of the motor is limited by the motor manufacturer to 3,000 RPM. Since the motor is generously sized, excess inlet pressure will cause it to overspeed. To limit the top speed and allow for full range control, a regulator and gauge are available.
- For intermittent duty, frequent generous oilings at the two oiling ports are recommended. For more continuous operation, the automatic air line lubricator is recommended.
- Air motor life is further enhanced by use of the filter.

**Accessories**

- Silencer
- Pressure Regulator
- Line Lubricator
- Line Filter

**Connections**

In	Out
¼" Male	¾" Male
½" Female	½" Female
½" Female	½" Female
½" Female	½" Female

**CAUSTIC SERVICE OPTION**

6C caustic seal is offered for Caustic Service: a 304s/s seal with high alumina ceramic vs carbon faces viton bellows.

Experience in the field has indicated the wisdom of establishing a limit to caustic soda (sodium hydroxide) liquid concentrations to 30% caustic in water and 175°F temperature.

Higher concentrations exhibit two related effects which have led to seal failures. First, crystalized solids in the pumpage immobilize the seal and leakage gets progressively worse although seal faces may appear undamaged. Secondly, the crystalization of leakage through the seal stops the seal from compensating for wear. The net effect in both cases is early seal failure.

If it is possible to flush the seal chamber with water, extended seal life is possible at higher caustic concentrations. This requires the addition of the flush hole in the pump backhead.

An external water source of sufficient pressure is necessary for the flush, warm water being more effective than cold water. The flush rate should be in the order of ½ gpm. The standard caustic seal should be used.

## PRODUCT INSPECTION AND TEST

The Products of Dean Brothers Pumps Inc. are subject to thorough and rigorous quality control and inspection procedures throughout the whole of the manufacturing process to

assure proper operation in full conformity with established performance standards.

## DEAN BROTHERS PRODUCT WARRANTY

We warrant to the purchaser from us of Dean Brothers products and parts of our own manufacture that such products and parts are free under rated use and service from defects in design, material and workmanship for a period of one (1) year from the date of installation, but not to exceed eighteen (18) months from the date of shipment by us. This warranty does not cover (I) any loss or damage resulting from wear, corrosion, abrasion or deterioration due to normal use in rated service; (II) replacement of service items such as shaft packings and mechanical seals; (III) products or parts manufactured by others but furnished by us which, if defective, shall be repaired or replaced only to the extent of the original manufacturer's warranty; or (IV) any loss or damages to or defects in any such products or parts resulting from the misuse or improper storage, installation or operation thereof.

We shall not be liable, directly or indirectly, under any circumstances for consequential or incidental damages, includ-

ing, but not limited, to: (I) any loss of business or profits; and (II) labor, material or other charges, claims, losses or damages incurred or suffered from, in connection with or in consequence of the working upon, alteration, or repair of any such defective products or parts by persons or firms other than us. Our liability for breach of warranty hereunder is limited solely to the repair in our factory or to the replacement F.O.B. our factory, as the case may be, of any products or parts which shall have been determined by us, after notice to us and inspection by us within the warranty period, to be so defective when shipped by us.

THIS WARRANTY AND THE LIABILITY SET FORTH HEREIN ARE EXCLUSIVE AND IN LIEU OF ALL OTHER LIABILITIES AND WARRANTIES, EXPRESS OR IMPLIED, INCLUDING IMPLIED WARRANTIES OF MERCHANTABILITY AND FITNESS FOR PARTICULAR PURPOSE.

## WARNING

Proper storage while not in use and proper installation and startup are essential for successful pump operation. Misuse or improper storage, installation or operation of pumps may result in serious loss or damage. Dean Brothers Pumps Inc. is not responsible for any loss or damage resulting from causes beyond its control, and is not liable for charges for work performed or materials furnished to repair such loss or damage.

### RECEIVING PUMP

When the pump is received from the transportation company, it should be promptly inspected for damage and such damage noted on the bill of lading before it is signed. Claims for shipping damage must be filed against the carrier.

Care should be exercised in unloading and handling the pump.

## SPARE PARTS

To avoid prolonged down time and facilitate rapid repair of damaged pump parts, Dean Brothers recommends that the pump user maintain a minimum stock of spare parts. If the pump service is critical or the pump parts are of special materials, a spare parts stock is even more important to the user. Such a spares inventory may extend from a spare mechanical seal or seal parts through complete backhead-impeller-motor assembly. Consult your Dean Brothers representative who will assist you in selecting your spares stock.

### ORDERING SPARE PARTS

Spare parts orders will be handled with a minimum delay if the

following information is furnished by the customer with the order:

- 1) Give the pump number. This may be found on the pump name plate.
- 2) Give the part name, part number, and material of part. These should agree with the standard parts list nomenclature.
- 3) Give the quantity of each part required.
- 4) Give complete shipping instructions.

## INSTALLATION AND MAINTENANCE

### INSTALLATION

The DL Pump can be installed in any position. The pump is furnished with 150#FF suction and discharge flanges cast in-line, maintaining simplified piping layouts. Suction lines should be short and straight to avoid excessive frictional losses. If larger piping is used on the suction side of the pump an eccentric reducer or means of venting the suction line should be provided to avoid the trapping of air or vapor. A centrifugal pump should be started with the suction valve open and the discharge valve either closed or opened a slight amount.

The pump stuffing box is arranged for mechanical seals only and no packing gland is required. Seals are installed at the factory and require no attention on installation or start-up of the pump.

### OPERATION

DL pump motors are furnished with prelubricated ball bearings. No lubrication is required at startup. When bearing replacement becomes necessary, install prelubricated, permanently sealed ball bearings.

### STARTING THE PUMP

1) A centrifugal pump should be started with the suction valve open and the discharge valve either closed or opened a slight amount.

2) When the source of liquid supplied to the pump is below atmospheric pressure or located below the pump, the pump must be primed prior to start up.

*A centrifugal pump should never be run without liquid in the casing. Extensive damage may result, particularly to the mechanical seal.*

3) Check all piping connections, making certain that connections are to the correct openings and that all connections are tight.

4) Check the electrical connections.

5) It is most important to check the direction of rotation of the pump before allowing the pump to come up to speed. To check rotation direction, push the starting button and instantly push the stop button. This will allow the motor to turn over a few revolutions and the direction of rotation to be observed. A direction of rotation arrow is shown on the side of the pump casing. If rotation direction is incorrect, change the wiring connections and recheck rotation. *Operating the pump in reverse rotation may cause extensive damage.*

6) After the pump is up to speed the discharge valve may be opened slowly. A centrifugal pump should not be operated for any appreciable time against a closed discharge valve since the liquid in the casing will begin to heat up.

### SERVICING

The pump may be serviced easily and quickly. It is not necessary to disconnect the piping or remove the pump casing from the line. The entire motor-adapter cradle-backhead-impeller

assembly is removed from the casing and may be taken to a convenient location for further servicing.

### DISASSEMBLY PROCEDURE

- a.) Always disconnect motor electrical leads.
- b.) Isolate pump casing to prevent spillage by closing suction and discharge valves.
- c.) Remove casing cover bolts Part # 5D.
- d.) Lift out pump and motor leaving casing in the line.
- e.) To remove impeller Part 3, place wrench on impeller nut and a large screw driver in slot provided in motor end of shaft to hold shaft when backing off impeller. Impeller turns off counter clockwise.
- f.) Backhead Part # 22 will slip free of adapter cradle Part # 7.
- g.) If motor is to be replaced, continue to dismantle Part # 7 from motor.
- h.) If seals are to be replaced, press out stationary unit Part # 95A from backhead Part # 22 and remove rotating seal face Part # 95B from impeller Part # 3.
- i.) Remove casing gasket Part # 77. Put in new gasket on reassembly.

### REASSEMBLY PROCEDURE

A new set of clearance shims together with a new casing gasket should be on hand to use as needed in the reassembly. Reassembly is a reverse of the above procedure. Whether using old or new parts, be sure that no foreign material, dirt, or grime is left on the parts. Before installing unit back into casing, put in new casing gasket Part #77.

Special care should be used in handling the mechanical seal. It should be kept clean at all times.

When all original pump parts are used, exclusive of mechanical seals, the shims Part # 37, which allow for proper impeller clearance, may be reused and are placed between the backhead Part #22 and adapter cradle Part # 7. If any new pump parts and/or new motors are used, other than the mechanical seal, be sure to order or have on hand new shims Part # 37 so that the following steps can be taken:

- 1) Remove all old shims Part # 37.
- 2) Slip backhead Part # 22 into adapter cradle Part # 7 and screw impeller Part # 3 onto motor shaft.
- 3) Measure the clearance with feeler gauge between the impeller Part # 3 and the backhead Part # 22. Be sure that backhead is tight to adapter cradle Part # 7 when taking the measurement.
- 4) Subtract .010" from your measurement of the impeller to backhead clearance and the resultant is the proper thickness of shim Part # 37 required to assure proper clearance for top pump performance.
- 5) Remove impeller and backhead and, installing the new shim, proceed with reassembly, reversing procedure (a) through (h). Pull down evenly on casing cap screws Part # 5D to about 125 pound-inches torque.

# DeanLine Pumps

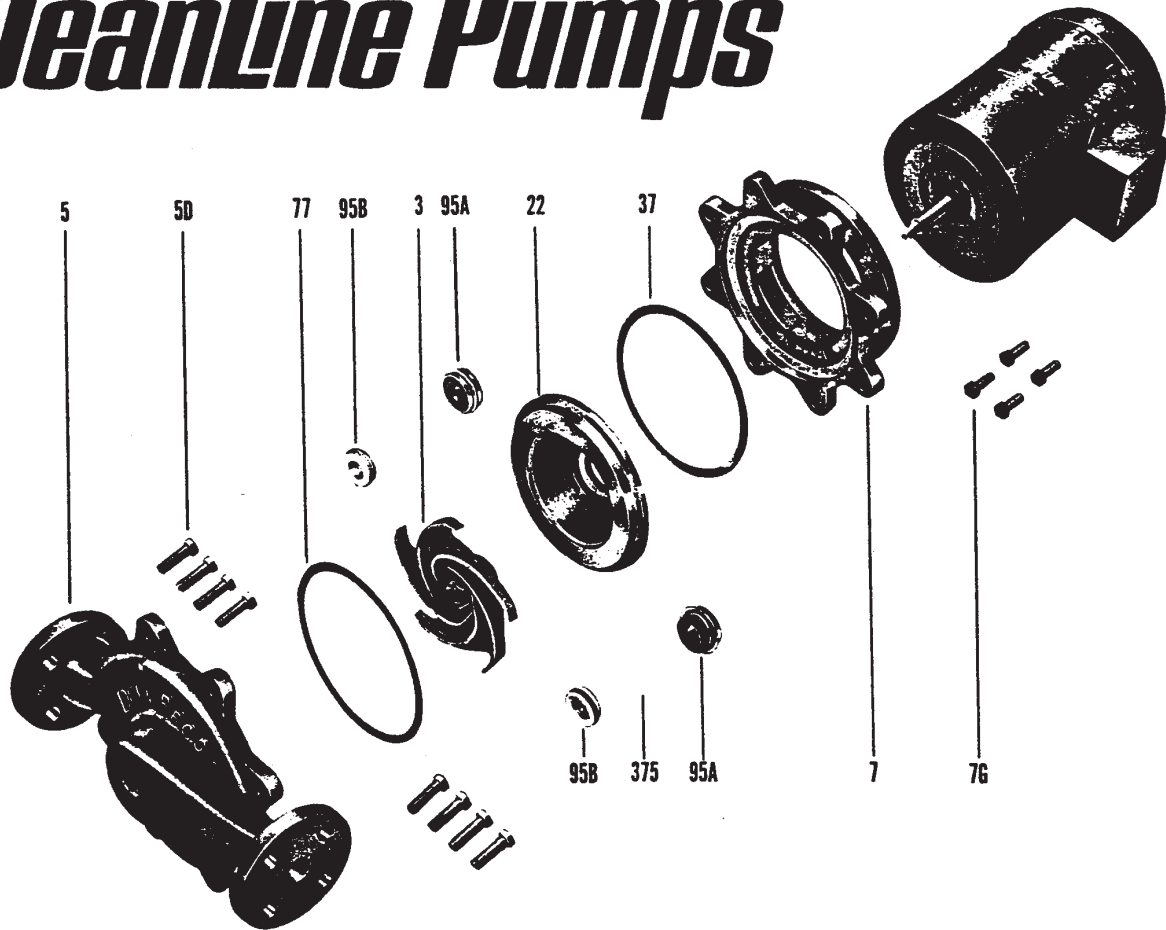

Part	Part No.	Deanalloy Class 20	Deanalloy Class 50
Impeller	3	C.I.	316ss
Casing	5	C.I.	316ss
Casing Cap Screw	5D	1020 Stl.	302ss
Adapter Cradle	7	C.I.	C.I.
Adapter Cap Screws	7G	1020 Stl.	1020 Stl.
Backhead	22	C.I.	316ss
Clearance Shim	37	Plastic	Plastic
Casing Gasket	77	Asbestos	Asbestos
Stationary Seal Element Stationary Face Spring Holder Shaft Packing	95A	Carbon 304ss Viton	Carbon 316ss 316ss Teflon
Rotating Seal Face	95B	Ceramic	Ceramic
Seal Dowel Pin	375	Not Required	316ss

*\*For caustic service, use Dean Type 6C Seal with High Alumina Ceramic*