

Hypertherm®

powermax900

PAC125T/M consumables

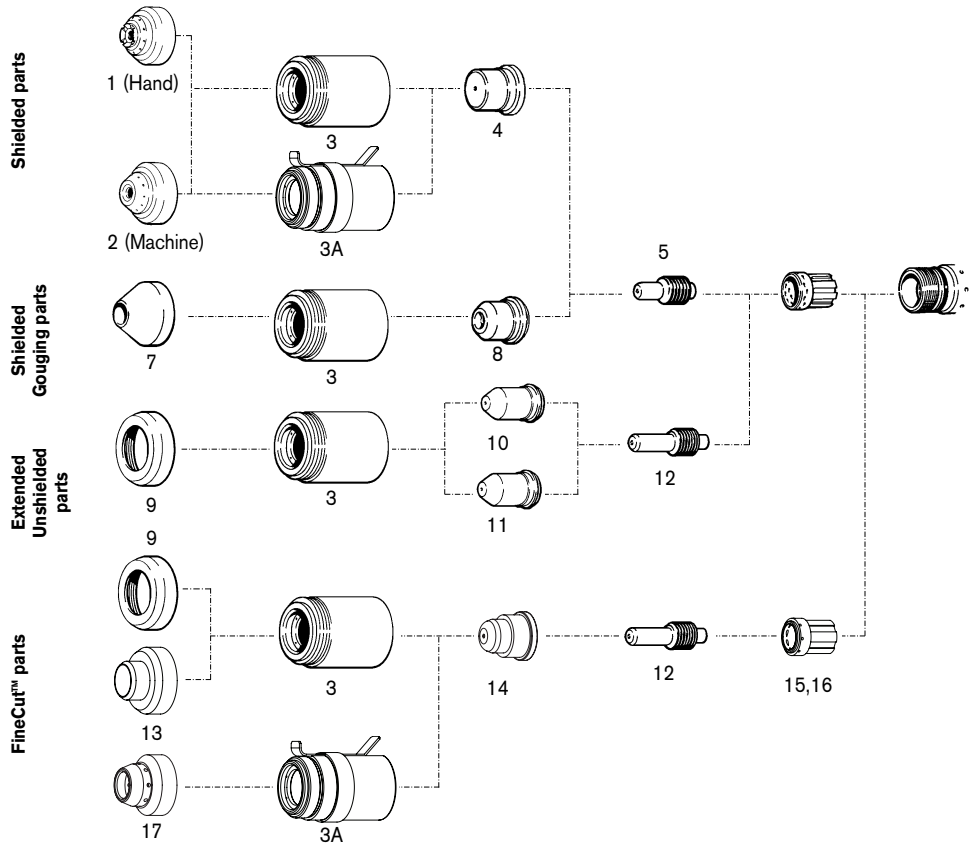

	ITEM NUMBER	PART NUMBER	DESCRIPTION	QUANTITY PER PACKAGE
Shielded parts	1	120601	Shield, Hand	1
	2	120602	Shield, Machine	1
	3	120600	Retaining Cap	1
	3A	120964	Retaining Cap, Ohmic	1
	4	120577	Nozzle	5
	5	120573	Electrode, Air	5
Shielded Gougung parts	6	120576	Swirl Ring	1
	7	120608	Shield, Gougung	1
	3	120600	Retaining Cap	1
	8	120607	Nozzle, Gougung	5
	5	120573	Electrode, Air	5
	6	120576	Swirl Ring	1
Extended Unshielded parts	9	120303	Deflector	1
	3	120600	Retaining Cap	1
	10	120578	Nozzle, Pipe Saddle, 55 Amp	5
	11	120606	Nozzle, Pipe Saddle, 35 Amp	5
	12	120574	Electrode, Extended	5
	6	120576	Swirl Ring	1
FineCut™ parts	9	120303	Deflector	1
	13	220326	Deflector, CE	1
	17	220403	Shield, Ohmic	1
	3	120600	Retaining Cap	1
	3A	120964	Retaining Cap, Ohmic	1
	14	220330	Nozzle	5
	12	120574	Electrode, Extended	5
15	220332	Swirl Ring, Hand	1	
16	120576	Swirl Ring, Machine	1	

Note: The nozzles and swirl rings shown must be used as a set.

Powermax900 PAC125T safety trigger torch assembly

For improved performance,
we recommend retrofitting
with the RT60 torch
(see page 35).

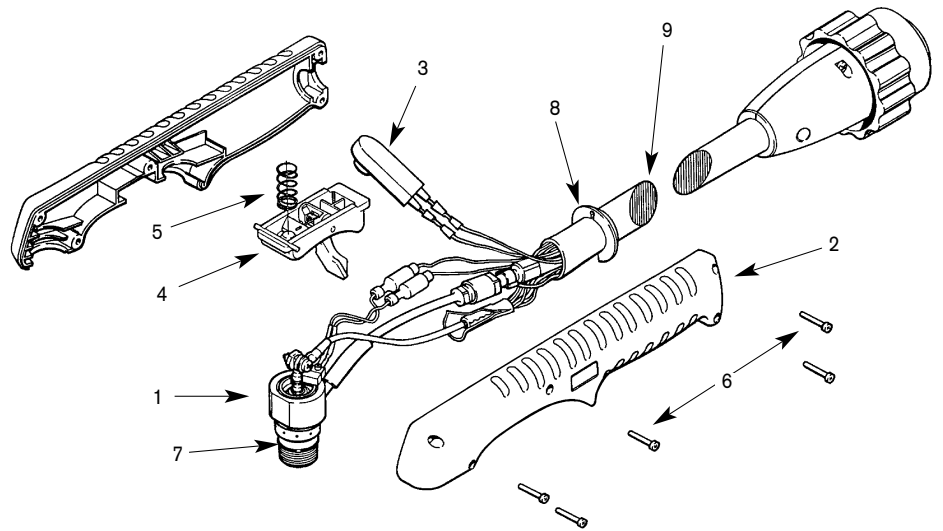

PAC125T

ITEM NUMBER	PART NUMBER	DESCRIPTION
	083066^	PAC125T Hand Torch Assembly, 25' / 7.6 m
	083067^	PAC125T Hand Torch Assembly, 50' / 15.2 m
1	120570	Torch Main Body with Switch
2	001288	Handle (includes both halves)
3	128284	Kit: Switch Repair
4	002244	Safety Trigger Assy
5	027254	Trigger Spring
6	075339	Screw, #4 x 1/2" (five required)
7	044016	O-Ring, Buna - N 90 Duro
8	004764	Ring, Gutcha
9	129352	PAC125T Torch Leads, 25' / 7.6 m
9	129353	PAC125T Torch Leads, 50' / 15.2 m

^ Assembly includes consumables

Powermax900 PAC125M torch assembly

For improved performance,
we recommend retrofitting
with the RT60 torch
(see page 37).

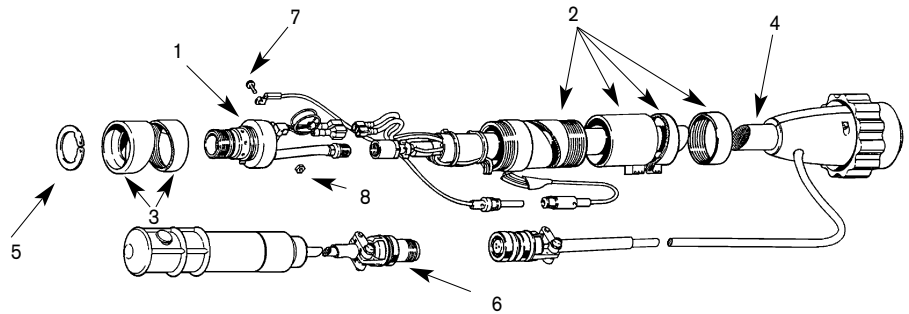

PAC125M

ITEM NUMBER	PART NUMBER	DESCRIPTION
	083069^	PAC125M Torch Assembly, with pigtail, 14' / 4.3 m Leads
	083068^	PAC125M Torch Assembly, with pigtail, 25' / 7.6 m Leads
	083070^	PAC125M Torch Assembly, with pigtail, 35' / 10.7 m Leads
	083071^	PAC125M Torch Assembly, with pigtail, 50' / 15.2 m Leads
	083073^	PAC125M Torch Assembly, without pigtail, 14' / 4.3 m Leads
	083072^	PAC125M Torch Assembly, without pigtail, 25' / 7.6 m Leads
	083074^	PAC125M Torch Assembly, without pigtail, 35' / 10.7 m Leads
	083075^	PAC125M Torch Assembly, without pigtail, 50' / 15.2 m Leads
1	120583	Torch Main Body with Switch, PAC125M
2	020620	Torch Position Sleeve
3	120613	Torch Sleeve
4	129339	Torch Lead, with pigtail, 14' / 4.3 m
4	129338	Torch Lead, with pigtail, 25' / 7.6 m
4	129340	Torch Lead, with pigtail, 35' / 10.7 m
4	129341	Torch Lead, with pigtail, 50' / 15.2 m
5	027599	Snap Ring
6	028714	On/Off Pendant, 25' / 7.6 m
6	128061	On/Off Pendant, 50' / 15.2 m
6	128062	On/Off Pendant, 75' / 22.9 m
7	075504	Screw, 4-40 x 5/16"
8	075503	Locknut, 4-40
4	129343	Torch Lead, without pigtail, 14' / 4.3 m
4	129342	Torch Lead, without pigtail, 25' / 7.6 m
4	129344	Torch Lead, without pigtail, 35' / 10.7 m
4	129345	Torch Lead, without pigtail, 50' / 15.2 m

^ Assembly includes consumables