

# Hypertherm®

## powermax800

### PAC121TS/125T consumables



Powermax800



PAC121TS/PAC125T

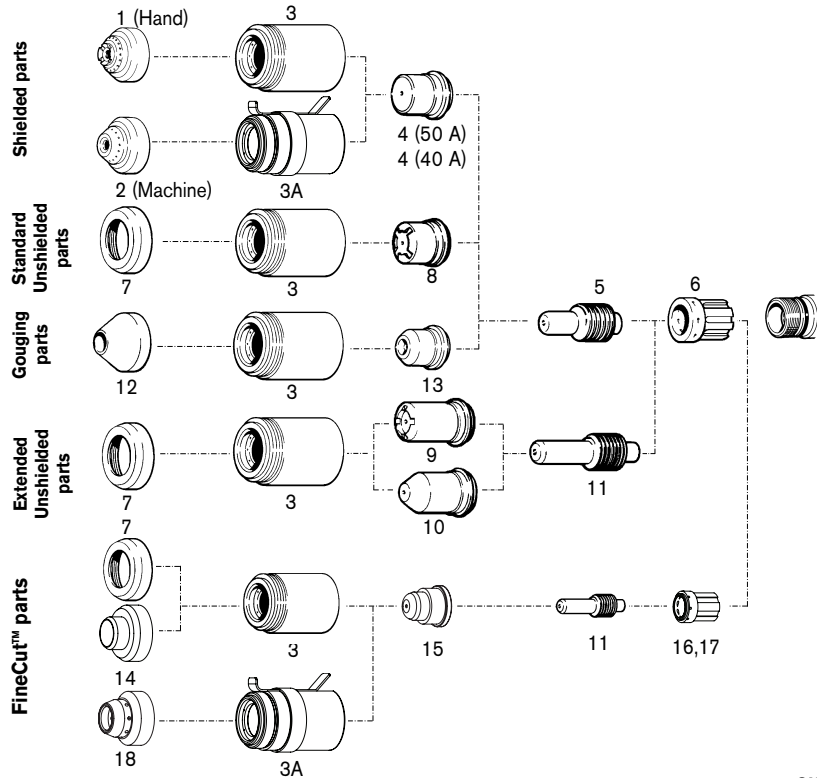

	ITEM NUMBER	PART NUMBER	DESCRIPTION	QUANTITY PER PACKAGE
Shielded parts	1	120601	Shield, Hand	1
	2	120602	Shield, Machine	1
	3	120600	Retaining Cap	1
	3A	220061	Retaining Cap, Ohmic	1
	4	120282	Nozzle, 50 Amp	5
	4	120438	Nozzle, 40 Amp	5
Standard Unshielded parts	5	120573	Electrode	5
	6	020361	Swirl Ring	1
	7	120303	Deflector	1
	3	120600	Retaining Cap	1
	8	020395	Nozzle, 50 Amp	5
Extended Unshielded parts	5	120573	Electrode	5
	6	020361	Swirl Ring	1
	7	120303	Deflector	1
	3	120600	Retaining Cap	1
	9	120304	Nozzle, Extended	5
Gouging parts	10	120305	Nozzle, Pipe Saddle	5
	11	120574	Electrode, Extended	5
	6	020361	Swirl Ring	1
	12	120608	Shield, Gouging, 50 Amp	1
	3	120600	Retaining Cap	1
FineCut™ parts	13	120281	Nozzle, Gouging, 50 Amp	5
	5	120573	Electrode	5
	6	020361	Swirl Ring	1
	7	120303	Deflector	1
	14	220326	Deflector, CE	1
	18	220403	Shield, Ohmic	1
	3	120600	Retaining Cap	1
3A	220061	Retaining Cap, Ohmic	1	
	15	220330	Nozzle	5
	11	120574	Electrode, Extended	5
	16	220332	Swirl Ring, Hand	1
	17	120576	Swirl Ring, Machine	1

**Note:** The nozzles and swirl rings shown must be used as a set.

# Powermax800 PAC121TS/125T safety trigger torch assembly

For improved performance, we recommend retrofitting with the RT60 torch (see page 35).

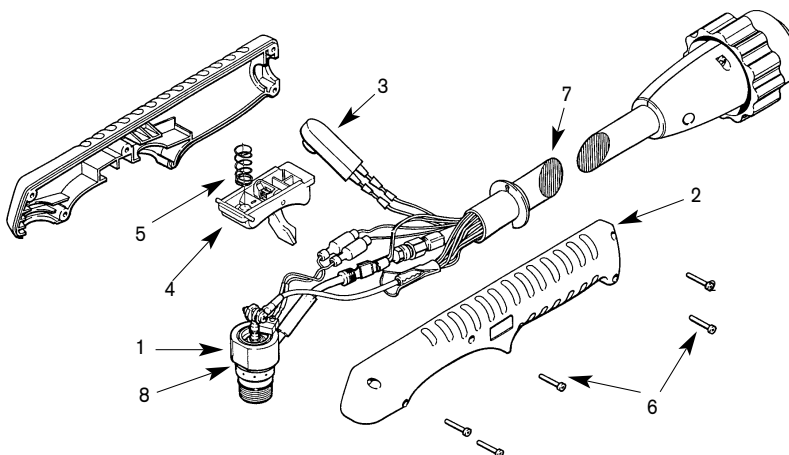

## PAC121TS



## PAC121TS/PAC125T

## PAC125T

ITEM NUMBER	PART NUMBER	DESCRIPTION
1	120556	Torch Main Body with Switch
2	001288	Handle (includes both halves)
3	128284	Switch, Torch Pushbutton
4	002244	Safety Trigger Assy
5	027254	Trigger Spring
6	075340	Screw, #4 x 5/8" (five required)
7	129001	PAC121TS Torch Leads, 25' / 7.6 m
7	129002	PAC121TS Torch Leads, 50' / 15.2 m
8	044016	O-Ring, Buna - N 90 Duro

ITEM NUMBER	PART NUMBER	DESCRIPTION
	083130^	PAC125T/Powermax800 Hand Torch Assembly, 25' / 7.6 m
	083131^	PAC125T/Powermax800 Hand Torch Assembly, 50' / 15.2 m
1	120570	Torch Main Body with Switch
2	001288	Handle (includes both halves)
3	128284	Switch, Torch Pushbutton
4	002244	Safety Trigger Assy
5	027254	Trigger Spring
6	075340	Screw, #4 x 5/8" (five required)
7	129352	PAC125T Torch Leads, 25' / 7.6 m
7	129353	PAC125T Torch Leads, 50' / 15.2 m
8	044016	O-Ring, Buna - N 90 Duro

^ Assembly includes consumables

**NOTE:** A label located on the torch handle indicates whether the torch is a PAC121TS or PAC125T

## Powermax800 PAC121M torch assembly

For improved performance,  
we recommend retrofitting  
with the RT60 torch  
(see page 37).

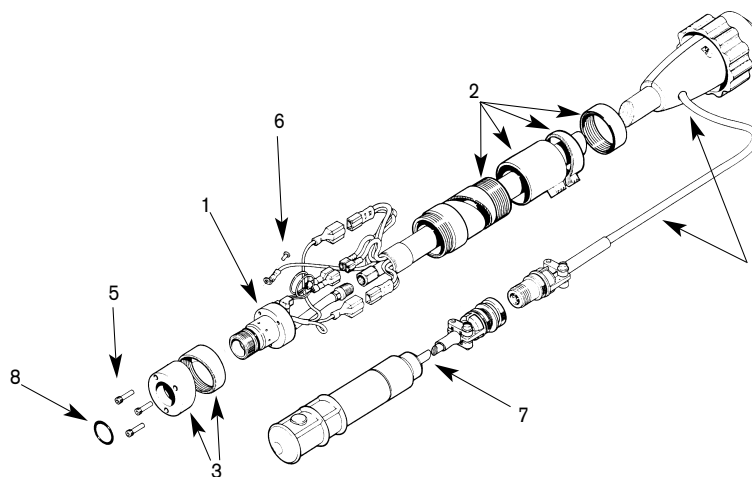

**PAC121M**

ITEM NUMBER	PART NUMBER	DESCRIPTION
1	120558	Torch Main Body with Switch
2	020620	Torch Position Sleeve
3	020559	Torch Sleeve
4	028923	Torch Lead, 14' / 4.3 m (with pigtail)
4	028918	Torch Lead, 25' / 7.6 m (with pigtail)
4	028926	Torch Lead, 35' / 10.7 m (with pigtail)
4	028919	Torch Lead, 50' / 15.2 m (with pigtail)
5	075321	Screw, 4-40 x 1/2, Hex, SS (three required)
6	075322	Screw, 4-40 x 1/4, SL, SZ
7	028461	On/Off Pendant, 25' / 7.6 m
7	028462	On/Off Pendant, 50' / 15.2 m
7	028463	On/Off Pendant, 75' / 22.9 m
8	044016	O-Ring: Buna 90 Duro .614 x .070
4	128123	Torch Lead, 14' / 4.3 m (without pigtail)
4	128125	Torch Lead, 25' / 7.6 m (without pigtail)
4	128126	Torch Lead, 35' / 10.7 m (without pigtail)
4	128127	Torch Lead, 50' / 15.2 m (without pigtail)

## Powermax800 PAC125 torch assembly

For improved performance,  
we recommend retrofitting  
with the RT60 torch  
(see page 37).

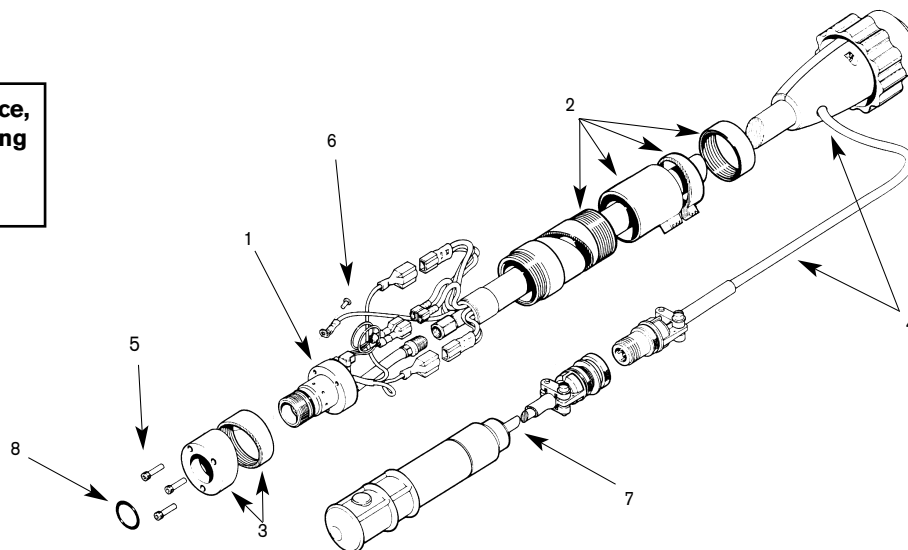

**PAC125M**

ITEM NUMBER	PART NUMBER	DESCRIPTION
	083136^	PAC125M Torch Assembly, 14' / 4.3 m Leads (with pigtail)
	083137^	PAC125M Torch Assembly, 25' / 7.6 m Leads (with pigtail)
	083138^	PAC125M Torch Assembly, 35' / 10.7 m Leads (with pigtail)
	083139^	PAC125M Torch Assembly, 50' / 15.2 m Leads (with pigtail)
	083140^	PAC125M Torch Assembly, 14' / 4.3 m (without pigtail)
	083141^	PAC125M Torch Assembly, 25' / 7.6 m (without pigtail)
	083142^	PAC125M Torch Assembly, 35' / 10.7 m (without pigtail)
	083143^	PAC125M Torch Assembly, 50' / 15.2 m (without pigtail)
1	120583	Torch Main Body with Switch
2	020620	Torch Position Sleeve
3	120613	Torch Sleeve
4	129339	Torch Lead, 14' / 4.3 m (with pigtail)
4	129338	Torch Lead, 25' / 7.6 m (with pigtail)
4	129340	Torch Lead, 35' / 10.7 m (with pigtail)
4	129341	Torch Lead, 50' / 15.2 m (with pigtail)
4	129343	Torch Lead, 14' / 4.3 m (without pigtail)
4	129342	Torch Lead, 25' / 7.6 m (without pigtail)
4	129344	Torch Lead, 35' / 10.7 m (without pigtail)
4	129345	Torch Lead, 50' / 15.2 m (without pigtail)
5	075321	Screw, 4-40 x 1/2, Hex, SS (three required)
6	075322	Screw, 4-40 x 1/4, SL, SZ
7	028714	On/Off Pendant, 25' / 7.6 m
7	128061	On/Off Pendant, 50' / 15.2 m
7	128062	On/Off Pendant, 75' / 22.9 m
8	044016	O-Ring: Buna 90 Duro .614 x .070

^ Assembly includes consumables